



## RS8090 SERIES ~ EMI Line Filter



RoHS Compliant

### PART NUMBERING SYSTEM

<b>RS</b>	<b>8090</b>	-	<b>220</b>	-	<b>LF</b>
TYPE	DIMENSIONS		INDUCTANCE		LEAD FREE

### SHAPES , DIMENSIONS AND PCB LAYOUT

UNIT : mm

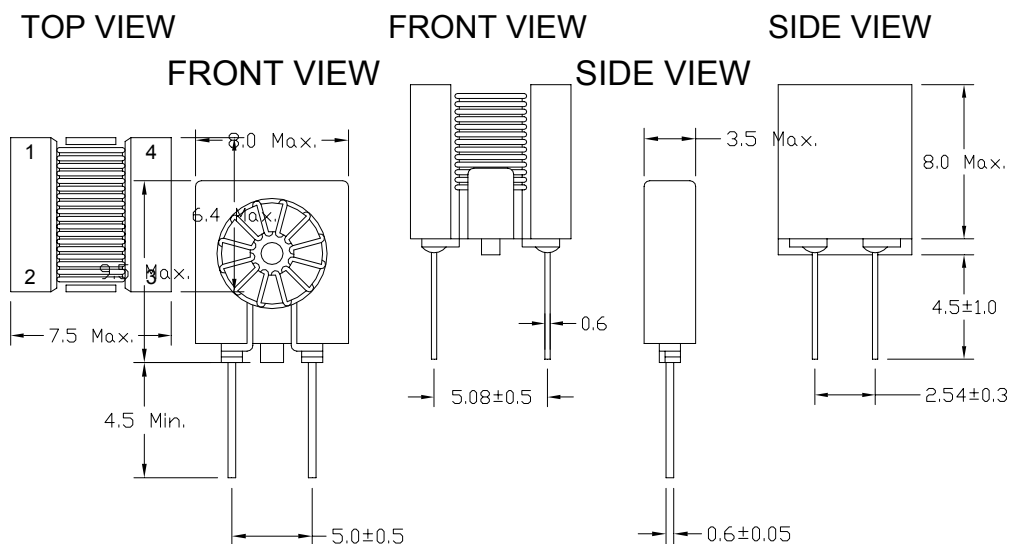

PART NUMBER	INDUCTANCE (μH)	DCR(mΩ) (Max.)	Rated Current (A)	Impedance ( Z ) ohm @100MHz (typ.)	Test Frequency ( KHz )
RS8090-4R7Y-LF	4.7±50%	20	0.50	300	1KHz/0.1V
RS8090-8R2Y-LF	8.2±50%	25	0.50	550	1KHz/0.1V
RS8090-100Y-LF	10±50%	25	0.50	600	1KHz/0.1V
RS8090-220Y-LF	22±35%	35	0.50	1100	1KHz/0.1V
RS8090-330Y-LF	33±35%	40	0.50	1500	1KHz/0.1V
RS8090-390Y-LF	39±35%	40	0.50	1600	1KHz/0.1V
RS8090-470Y-LF	47±35%	50	0.50	1700	1KHz/0.1V
RS8090-560Y-LF	56±35%	60	0.50	2000	1KHz/0.1V
RS8090-600Y-LF	60±35%	89	0.50	2300	1KHz/0.1V
RS8090-820Y-LF	82±35%	110	0.50	2500	10 KHz/0.1V
RS8090-101Y-LF	100±35%	170	0.50	3000	10 KHz/0.1V
RS8090-121Y-LF	120±35%	200	0.50	3200	10 KHz/0.1V

- Operating temperature range -40°C to +85°C , Electrical specifications at 25°C.