



SDC8D28 SERIES

SMD Shielded Power Inductors



RoHS Compliant

PART NUMBERING SYSTEM

SDC	8 D 2 8	—	6 8 0 N	—	LF
TYPE	DIMENSIONS		INDUCTANCE		LEAD FREE

SHAPES AND DIMENSIONS

UNIT : mm

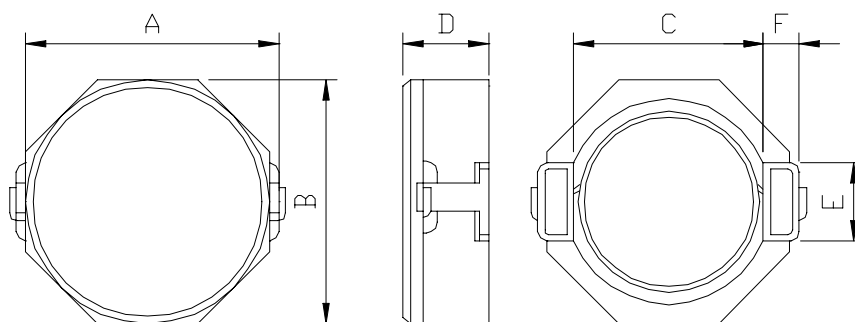

A=8.3 max. B=8.3 max. C=6.3 REF D=3.0 max. E=2.5 REF F=1.2 REF

RECOMMENDED PATTERNS

UNIT : mm

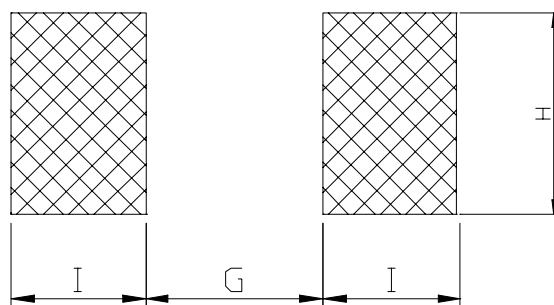

H= 2.80 G= 6.10 I = 2.00 J =2.00

FEATURES

- Low profile (3.00mm max. height) and 8.3mmx8.3mm max. square.
- Magnetically shielded and low DC resistance .
- Tape and Reel packaging for pick and place assembly .
- Ideal for a variety of DC-DC converter inductor , LCD panels , DVD players Computer and portable power devices applications .



SDC8D28 SERIES

SMD Shielded Power Inductors



RoHS Compliant

ELECTRICAL CHARACTERISTICS :

PART NUMBER	INDUCTANCE (μ H)	DCR (m Ω) (Max.)	Isat (A) (Max.)	Irms (A) (Max.)	TEST FREQ. (f)
SDC8D28-1R0N-LF	1.0 \pm 30%	11.0	6.50	7.00	100KHz
SDC8D28-2R5N-LF	2.5 \pm 30%	15.6	4.50	6.40	100KHz
SDC8D28-3R3N-LF	3.3 \pm 30%	18.2	4.00	6.00	100KHz
SDC8D28-4R7N-LF	4.7 \pm 30%	24.7	3.40	4.50	100KHz
SDC8D28-7R3N-LF	7.3 \pm 30%	39.0	2.80	3.40	100KHz
SDC8D28-100N-LF	10 \pm 30%	47.0	2.50	3.20	100KHz
SDC8D28-150N-LF	15 \pm 30%	69.0	1.90	2.30	100KHz
SDC8D28-220N-LF	22 \pm 30%	99.0	1.60	1.85	100KHz
SDC8D28-330N-LF	33 \pm 30%	156	1.30	1.45	100KHz
SDC8D28-470N-LF	47 \pm 30%	195	1.15	1.30	100KHz
SDC8D28-680N-LF	68 \pm 30%	286	0.92	0.98	100KHz
SDC8D28-101N-LF	100 \pm 30%	430	0.75	0.80	100KHz

- Isat : DC current at which the inductance drops 35% (typ) from its value without current.
- Irms: The actual current when temperature of coil becomes Δ 40°C . (Ta=+20°C)
- Operating temperature range -40°C to +85°C , Electrical specifications at 20°C.

PACKAGING SPECIFICATION

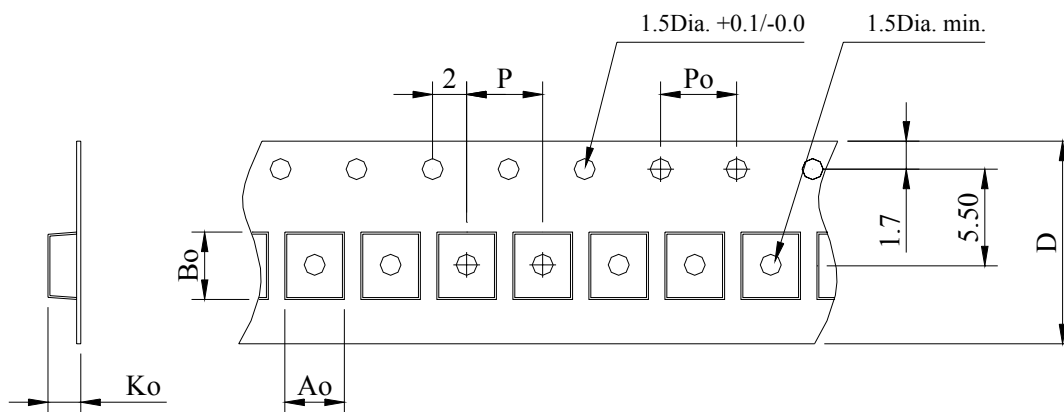

STAYLE	Q' TY (PCS)	DIMENSIONS (m/m)					
		A_o	B_o	K_o	P	P_o	$D\pm 0.3$
13-16	1,000	10.5	8.2	3.1	16.0	4.00	16.0