



SDS74H SERIES ~ SMD Shielded Power Inductors



RoHS Compliant

PART NUMBERING SYSTEM

SDS	74H	100M	LF
TYPE	DIMENSIONS	INDUCTANCE	LEAD FREE

SHAPES AND DIMENSIONS

UNIT : mm

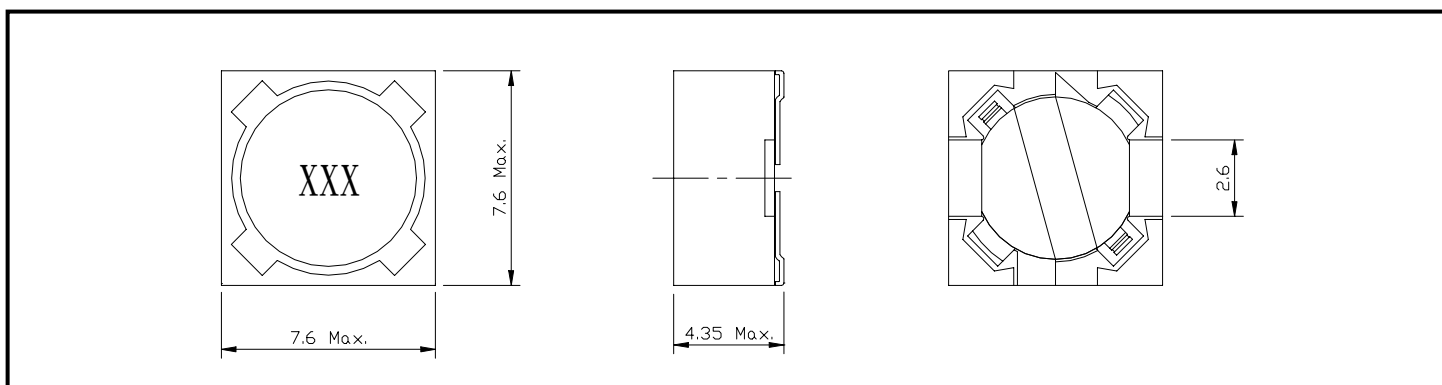

PACKAGING SPECIFICATION

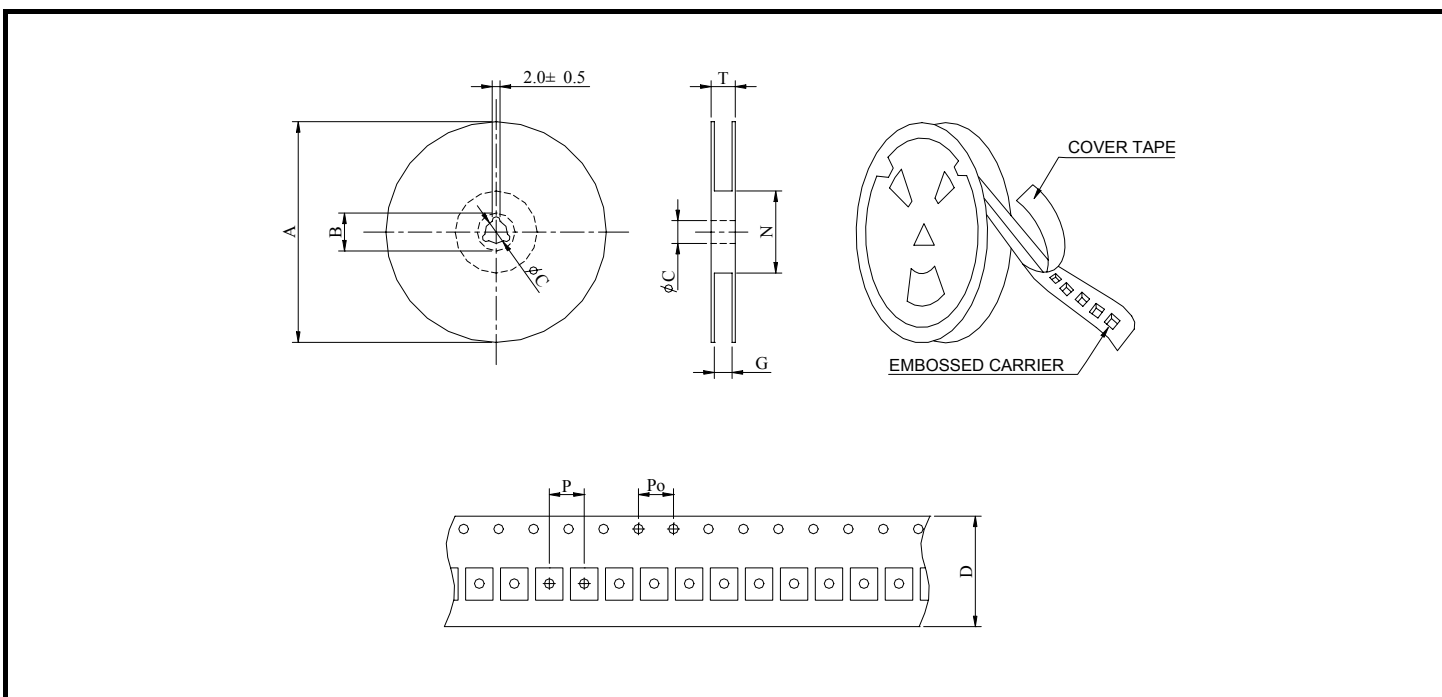

SERIES	STAYLE	Q' TY (PCS)	DIMENSIONS (m/m)								
			A	B±0.8	C±0.5	D	G ⁺⁰	N ⁰	P	Po	T
SDS74H	13-16	1000	330	21	13	16	18	50	8	4	22.4



SDS74H SERIES ~ SMD Shielded Power Inductors



RoHS Compliant

SPECIFICATION TABLE

PART NUMBER	INDUCTANCE (μ H)	DCR (Ω) (Max.)	IDC (A) (Max.)	TEST FREQ. (f)
SDS74H-R33M-LF	0.33 \pm 20%	0.0096	18.4	100KHz
SDS74H-1R0M-LF	1.00 \pm 20%	0.0129	10.2	100KHz
SDS74H-1R5M-LF	1.50 \pm 20%	0.0154	8.35	100KHz
SDS74H-2R2M-LF	2.20 \pm 20%	0.0164	7.06	100KHz
SDS74H-3R3M-LF	3.30 \pm 20%	0.0238	5.40	100KHz
SDS74H-4R7M-LF	4.70 \pm 20%	0.0331	4.37	100KHz
SDS74H-6R8M-LF	6.80 \pm 20%	0.0544	3.67	100KHz
SDS74H-8R2M-LF	8.20 \pm 20%	0.0574	3.40	100KHz
SDS74H-100M-LF	10 \pm 20%	0.0636	3.17	100KHz
SDS74H-150M-LF	15 \pm 20%	0.0829	2.48	100KHz
SDS74H-220M-LF	22 \pm 20%	0.1203	2.13	100KHz
SDS74H-330M-LF	33 \pm 20%	0.1859	1.73	100KHz
SDS74H-470M-LF	47 \pm 20%	0.2808	1.41	100KHz
SDS74H-680M-LF	68 \pm 20%	0.3345	1.19	100KHz
SDS74H-820M-LF	82 \pm 20%	0.4485	1.11	100KHz
SDS74H-101M-LF	100 \pm 20%	0.4979	0.99	100KHz
SDS74H-151M-LF	150 \pm 20%	0.7683	0.81	100KHz
SDS74H-221M-LF	220 \pm 20%	1.1791	0.66	100KHz
SDS74H-331M-LF	330 \pm 20%	1.8330	0.54	100KHz
SDS74H-471M-LF	470 \pm 20%	2.2620	0.46	100KHz
SDS74H-681M-LF	680 \pm 20%	3.3540	0.38	100KHz
SDS74H-821M-LF	820 \pm 20%	3.8090	0.35	100KHz
SDS74H-102M-LF	1000 \pm 20%	5.0570	0.31	100KHz

- DC current at which the inductance drops 30% (typ) from its value without current.
- Operating temperature range -40°C to +85°C.
- Electrical specifications at 20°C .